

# Site Installation Manual

# JuicePump



TRI125-175-S (USA)

175 kW DC

# Contents

<b>1</b>	<b>Overview.....</b>	<b>3</b>
1.1	Purpose of this document.....	3
1.2	Disclaimer and warranty.....	3
1.3	Acronyms and abbreviations.....	3
1.4	Identifying symbols.....	4
1.5	Specifications.....	5
1.6	<b>IMPORTANT SAFETY INSTRUCTIONS.....</b>	<b>6</b>
1.7	Grounding.....	10
1.8	Wiring.....	10
1.9	Ratings.....	11
1.10	Usage limitations.....	11
1.11	Installation safety considerations.....	12
1.12	References and related documents.....	12
<b>2</b>	<b>Site plan.....</b>	<b>13</b>
2.1	Block diagram.....	13
2.2	Layout.....	14
<b>3</b>	<b>Resources.....</b>	<b>15</b>
3.1	Tools and consumables.....	15
3.2	Heavy equipment.....	16
3.3	Torques utilized during installation.....	16
<b>4</b>	<b>Installation.....</b>	<b>17</b>
4.1	Conduit and cabling.....	17
4.2	Upstream protection.....	17
4.3	Earthworks.....	18
4.4	HPC equipment storage recommendations and conditions.....	18
4.5	High-power electrical connections.....	20
4.6	Isolated power unit installation.....	21
4.7	UU installation.....	29
<b>5</b>	<b>Site installation handover.....</b>	<b>34</b>
5.1	Pre-checks.....	34
5.2	Polarity, cross-wire, and bolted short test.....	34

# 1 Overview

## 1.1 Purpose of this document

The purpose of this document is to provide qualified electrical engineers and manufacturer-certified installers with an outline of the steps required to install a JuicePump 175-S high-power charging 175 kW site.

This document is for both the single and dual cable variants of the JuicePump 175-S.

**Note:** The images used in this document are of the dual cable variant.

## 1.2 Disclaimer and warranty

This manual sets out the manufacturer's understanding of best-practice methodologies and its requirements for installation of the JuicePump 175-S.

The manufacturer encourages all owners of its products to consult a qualified engineering consultancy firm to provide independent advice on the methodologies set out in this manual and site design requirement, including in relation to applicable regulatory and statutory requirements. All site designs must be signed off on by a professional engineer.

The manufacturer accepts no liability for any loss caused, whether due to negligence or otherwise arising from the strict adherence to the requirements set out in this manual in contravention of local regulatory and legal requirements.

It is an express condition of the manufacturer's warranty that:











- The requirements set out in this manual are adhered to (subject to local regulatory and legal requirements) when installing the JuicePump 175-S; and
- The installation is conducted by a manufacturer-certified technician who has completed the manufacturer's installation training course for the JuicePump 175-S.

## 1.3 Acronyms and abbreviations

Acronym/abbreviation	Definition
CID	Component Identifier
DIN	Deutsches Institut für Normung The German national standards organization. DIN rail is a metal rail of a standard type widely used for mounting circuit breakers. DIN Connectors and DIN wiring
DMM	Digital Multimeter
HMI	Human Machine Interface
HPC	High Powered Charging
IMI	Insulation Monitoring Interrupter
IP	Internet Protocol
IPU	Isolated Power Unit.
JuicePump175-S Solution	TR1125-175 - JuicePump 175 kW RT 175-S Solution Comprised of a single IPU and a pair of UU.
LV	Low Voltage
LVR Kit	Low Voltage Rescue Kit
PE	Protective Earth

Acronym/abbreviation	Definition
PCB	Power Circuit Board
PU	Power Unit
UU	User Unit
UV	Undervoltage

## 1.4 Identifying symbols

Symbol	Meaning
	CRITICAL
	CAUTION
	RISK OF ELECTRIC SHOCK
	Dangerous voltage
	Direct Current (DC)
	Phase Symbol
	Alternating Current Supply Symbol
	3-Phase Alternating Supply (no neutral connection)
	Operators Manual; Operating Installations
	Read Operators Manual

## 1.5

## Specifications

Unit	Specifications
LV Distribution Board	<ul style="list-style-type: none"><li>• 185 kVA Output per charger</li><li>• 400 V/300 A 50 Hz, 480 V/250 A 60 Hz, 600 V/200 A 60 Hz</li><li>• UL-listed circuit breakers with optional under-voltage relay</li><li>• Maximum available fault current of 18 kA (current limiting fuses or current limiting circuit breakers may be required to maintain limit of 18 kA)</li><li>• Residual current monitoring device of time delay type (optional)</li></ul>
Isolated Power Unit	<ul style="list-style-type: none"><li>• 1 x 185 kVA double insulated safety isolation transformer</li><li>• 1 x 175 kW AC/DC converter with AC contactors</li><li>• Integrated Communications Unit, Dual 4G SIM</li><li>• 800 kg</li></ul>
User Unit	<ul style="list-style-type: none"><li>• 1 x 175 kW 350 A DC/DC converter (CCS/CHAdEMO)</li><li>• 260 kg</li></ul>

## 1.6

# IMPORTANT SAFETY INSTRUCTIONS

## SAVE THESE INSTRUCTIONS

The instructions must be followed during installation, operation, and maintenance of the unit.



### Warning!

**These instructions must be read prior to installation of the unit.**



This manual contains important instructions for the JuicePump 175-S 175 kW DC electric vehicle fast charger

The instructions shall be followed during installation, operation, and maintenance of the unit.



### Warning!

#### **Danger due to installation location**

Installation shall not be made in a commercial garage (repair facility) or closer than 20 feet / 6096 mm of an outdoor motor fuel dispensing device.



### Warning!

#### **Danger due to incorrect installation or servicing**

The installation must be conducted by a manufacturer Certified technician who has completed the manufacturer's installation training course for the JuicePump 175-S.

The JuicePump 175-S fast charger system must be installed and serviced only by qualified electrical personnel (subject to local regulatory and legal requirements.)



### Caution!

#### **Danger due to incorrectly tightened terminals**

This may result in heat damage to the charger, which may lead to fire.

When connecting AC and DC cables, ensure that all the terminals are tightened to the specified torque.



## Warning!

### Danger due to inadequate ground conductor connection

This can result in serious injury and damage to property.

- This document provides guidelines for earth connections for the charger and the wiring of the system.
- Connections to the battery charger shall comply with all local codes and ordinances.



## Warning!

### Cord extensions or adaptors could cause over heating serious injury or fire

- Cord extension sets or second cable assemblies shall not be used in addition to the cable assembly for the connection of the vehicle to the charger.
- Adaptors shall not be used to connect a vehicle connector to a vehicle inlet.



## Warning!

### Incorrect fusing or input over current device can compromise the electrical safety of this charger and could result in serious injury or fire

Available short-circuit fault current for the RT 175-S must not exceed 18 kA. This means that a current-limiting fuse or circuit breaker may be required in locations where site fault current availability exceeds this value.



## Caution!

### Risk of fire

To reduce the risk of fire, connect only to a circuit provided with 320 A maximum branch circuit overcurrent protection in accordance with the National Electrical Code, ANSI/NFPA 70.



## Warning!

### Danger when lifting units

The rain hood and spacers are not appropriately rated for lifting the unit. Failure to remove them may cause damage to the IPU and/or serious accident.

NEVER lift the IPU in a horizontal position if the primary transformer has been installed. The cabinet is not rated for this.







## Warning!

### Conduit and cabling

Prior to installation of the piping and wiring, a professional review of local requirements must be performed to ensure that laws and regulations are adhered to. As a result, it may be required to deviate from the requirements of this documentation.

**Note:** Deviations from these instructions must not reduce the effective safety and integrity of the installation and the product.



## Warning!

### Piping and wiring

Prior to installation of the piping and wiring, a professional review of local requirements must be performed to ensure that laws and regulations are adhered to. As a result, it may be necessary to deviate from the cable lug sizes (and corresponding cable sizes) referenced in this manual.



## Warning!

### Earthing electrode

- For EMC compliance, it is important that a local earthing electrode is used to bond the chassis of the IPU directly to ground. This may be in the form of an earth stake, or if available, can be bonded to pre-existing buried earth structures.
- Prior to installation of the unit, a professional review of local lightning protection requirements must be performed to ensure that laws and regulations are adhered to. As a result, it may be necessary to install additional earthing electrodes for outdoor installations.



## Warning!

**Be aware that lifting heavy loads that are inadequately secured, could damage the product and cause serious injury**

Be careful as the unit may swing. A second operator may be required to control the UU lift.

## 1.7

### Grounding



#### Warning!

##### **Danger due to inadequate ground conductor connection**

This can result in serious injury and damage to property.

- This document provides guidelines for earth connections for the charger and the wiring of the system.
- Connections to the battery charger shall comply with all local codes and ordinances.

This unit must be connected to a grounded, metal, permanent wiring system, and an equipment-grounding conductor must be run with circuit conductors and connected to equipment-grounding terminal or lead on the electric vehicle charger.

- Connections to the battery charger shall comply with all local codes and ordinances.
- Electrical Connections to the RT 175-S PU and UU and interconnection cables and conduit shall comply with all local codes and ordinances. Including all connections to grounding conductor and earthing electrodes.

## 1.8

### Wiring

Power and protective earth (PE) Conductor ratings:

- DC copper 95 mm<sup>2</sup> (cross section)
- V90 class, rated to operate at 90°C.

The manufacturer recommends the use of copper cables. Refer to the following JuicePump 175-S document for reference specifications - *TRI125.INS.016 ENEL X 175-S Piping and Cabling*.

Take care to observe local regulations regarding wiring different circuits in the same conduit, including the Ethernet link if used.

In general, all conductors occupying the same conduit shall have an insulation rating equal to at least the maximum circuit voltage applied to any conductor within the conduit.

## 1.9

### Ratings

#### Input

##### User Unit

950 VDC 190 A

1Ø, 240 VAC, 3 A, 50/60 Hz

The JuicePump user unit must be connected to a circuit provided with appropriate over-current protection in accordance with the national, regional, and local regulations in the country of installation.

#### Torque Settings

See section 3.3. *Torques utilized during installation.*

#### Input

##### Power Unit:

400 VAC 3~, 50 Hz, 270 A, or

480 VAC 3~, 60 Hz, 225 A, or

600 VAC 3~, 60 Hz, 200 A

For more information refer to the following datasheet:

- *TRI125.DTA.009 JuicePump RT175-S Datasheet (covers UU and PU)*

**Note:** IPU ratings are region dependent; ensure you have the correct equipment for your region.

#### Weather Rating

PU IP55, NEMA 3R

UU IP65, NEMA 3R

## 1.10

### Usage limitations



#### Warning!

##### **Cord extensions or adaptors could cause over-heating, serious injury, or fire**

- Cord extension sets or second cable assemblies shall not be used in addition to the cable assembly for the connection of the vehicle to the charger.
- Adaptors shall not be used to connect a vehicle connector to a vehicle inlet.

## 1.11 Installation safety considerations

- First Aid Kit
- LVRK
- Defibrillator
- Never walk under suspended loads
- Site shall never be worked on while electrically live. Before any duty, ensure LV distribution board circuit breakers are isolated and locked out.
- Fencing and exclusion zones, authorization from the local authorities
- Exclusion zones when lifting hardware
- Shelter from weather (sun, wind, dust, and rain)
- Second person in the event of an accident

## 1.12 References and related documents

- TRI125.INS.016 JuicePump RT175-S Piping and Cabling
- TRI125.INS.019 JuicePump RT175-S User Unit Installation Manual
- TRI125.INS.033 JuicePump RT175-S Maintenance Manual
- TRI125.DTA.009 JuicePump RT175-S Datasheet (covers UU and PU)
- TRI125.CHK.008 JuicePump RT175-SK System Installation Checklist

## 2

## Site plan

### 2.1

### Block diagram

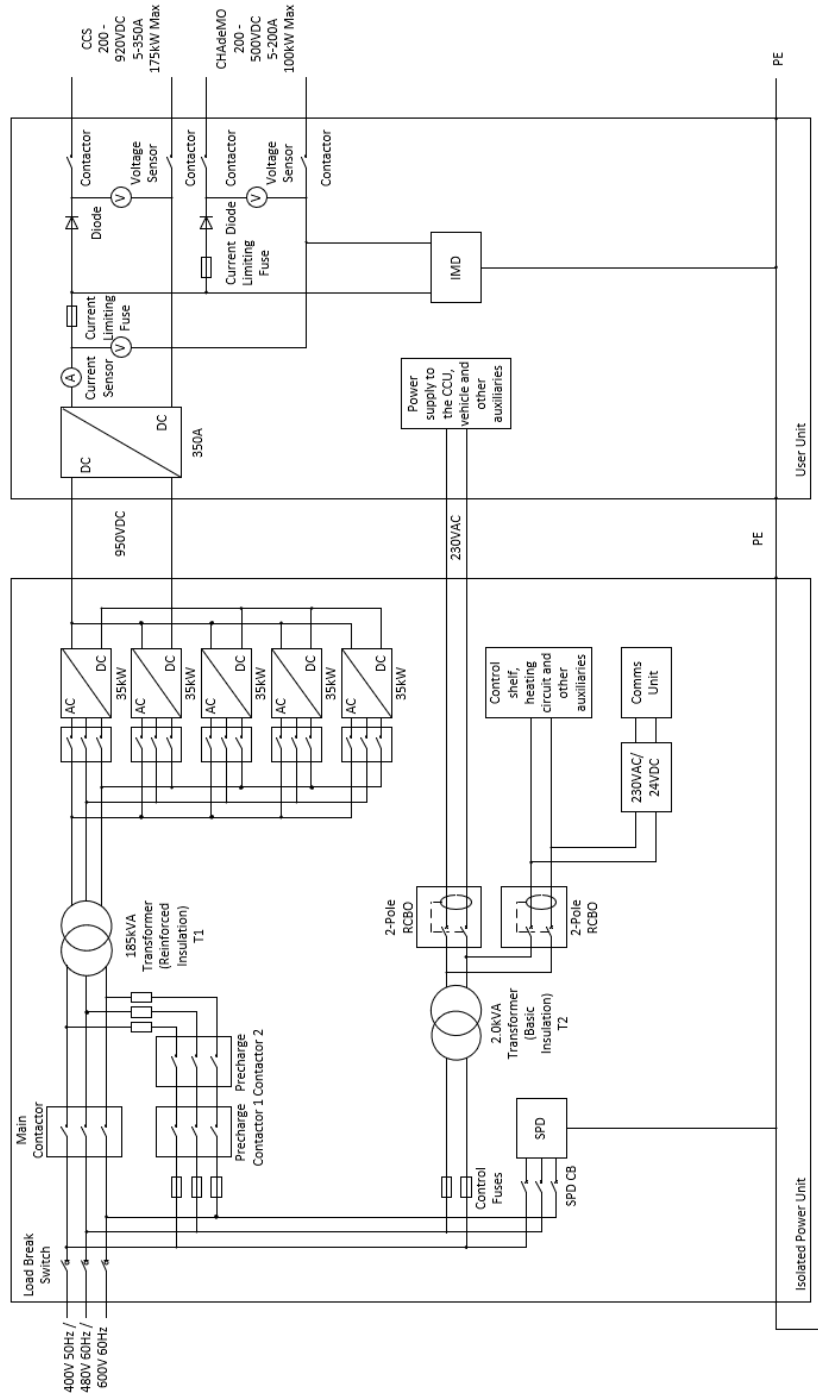

Figure 1: Single charger block diagram

## 2.2

## Layout

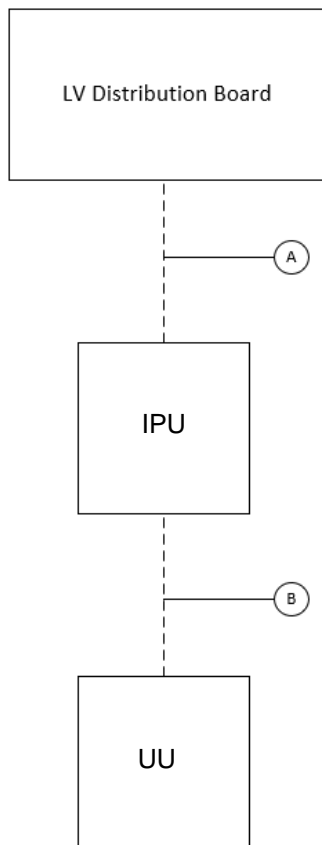

Figure 2: Site electrical layout

## 3 Resources

### 3.1 Tools and consumables

#### 3.1.1 Tools

- Network termination equipment
- Electric hydraulic cable lug terminator
- 100 m hook-up wire
- 4 x 1 T (minimum) rated lifting straps
- Rags
- Electric caulking gun
- Drill
- Torque wrench
- Step ladder
- Table
- Chair
- General tools:
  - Spanners
  - Shifters
  - Socket Set >24 mm
  - Screwdrivers
  - Side cutters
  - Hex keys
  - Knife
  - Multi-grip pliers

#### 3.1.2 Consumables

Ensure that the appropriately-sized cable termination lugs for the AC and DC installation wiring are procured, as well as the required heat-shrink to demark three-phase AC cabling, high-powered DC cables, and protective earth cables.

Glands for customer cabling to and from the IPU must also be installer supplied. Glands for the user unit are supplied in the installation kit for that region.

CID	Description	QTY
12942 OR 12943	RT 175-S Installation Kit (CID is region dependent). <b>Note:</b> Does not contain any DIN standard lugs.	-
5542	UL Listed Cable Tie, Yellow, 100 x 2.5 mm, PK100	200
6234	UL Listed Cable Tie, 94 V-2, 292 mm x 4.8 mm Black, Panduit, PK100	1
8405	Cable Ties, Black, 450 x 8 mm, Heavy Duty, 100 pack	1
9543	NOFIRNO(R) Cable Sealant	-
9127	Category 6a 10 G Shielded Keystone Slimline Jack Toolless 180° IDC	2
9416	Category 6a S/FTP LSZH 1.5 m RJ45-RJ45 Network Cable: Blue	2
9565	Molex 44915 Series Number Cat6 8P8C Way Cable Mount RJ45 Modular Plug Male	2
5792	EJCC Copper Jointing Compound	125 ml
2567	Aluminum Jointing Compound	125 ml

**Note:** Due to difficulties shipping jointing compound, copper and aluminum, compound must also be installer-supplied as needed.

### 3.2 Heavy equipment

- Crane – with 7 m reach, 1 T lift capacity
- Forklift
- Temporary weather shelter

### 3.3 Torques utilized during installation

Equipment	Thread code	Position	Torque (Nm)
<b>UU</b>	M5	Hatch cover	2
	M8	Ground	16
	M8 post hex	Outer covers	4
	M10	DC	30
	M12/16	Chassis mount	30/40
<b>IPU</b>	M10	DC	30
	M10	AC, Ground	30
	M12	Chassis mount	30



## 4 Installation

### 4.1 Conduit and cabling



#### Warning!

##### Conduit and cabling

Prior to installation of the piping and wiring, a professional review of local requirements must be performed to ensure that laws and regulations are adhered to. As a result, it may be required to deviate from the requirements of this documentation.

**Note:** Deviations from these instructions must not reduce the effective safety and integrity of the installation and the product.

Refer to *TRI125.INS.016 JuicePump RT 175-S Piping and Cabling*.

Site electrical design must be carried out and approved by a suitably qualified professional. Prior to commissioning, the electrical installation must be signed off as safe, complete, and compliant to local laws and regulations.

### 4.2 Upstream protection

#### 4.2.1 Device selection

Maximum sizes for the upstream electrical protective equipment supplying the RT 175-S IPU are as described in the following table.

Electrical Network	RT 175-S Maximum Demand	Recommended Size	Maximum Size <sup>2</sup>
600 VAC 3 PH, 60 Hz	200 A	250 A <sup>1</sup>	250 A
480 VAC 3 PH, 60 Hz	250 A	320 A <sup>1</sup>	320 A
400 VAC 3 PH, 50 Hz	300 A	320 A	350 A

<sup>1</sup> Recommended sizes for North American markets are selected according to NEC article 625, accounting for the 125% rule.

<sup>2</sup> The over-current protection device rating must not exceed these values in order to maintain primary protection for the LV transformer within the IPU.



#### Warning!

**Incorrect fusing or input over current device can compromise the electrical safety of this charger and could result in serious injury or fire**

Available short-circuit fault current for the RT 175-S must not exceed 18 kA. This means that a current limiting fuse or circuit breaker may be required in locations where site fault current availability exceeds this value.



## Caution!

### Risk of fire

To reduce the risk of fire, connect only to a circuit provided with 320 A maximum branch circuit overcurrent protection in accordance with the National Electrical Code, ANSI/NFPA 70.

### 4.2.2 Optional under-voltage relay

The IPU includes pre-wired terminals to allow the optional use of an under-voltage device at the upstream supply breaker. The pre-wired terminals supply a normally closed 230 VAC signal to allow upstream isolation in the event of a RT 175-S safety loop trip (for example, tilt-switch or cabinet door switch).

The use of an upstream under-voltage trip is optional, as the IPU locally isolates via the input contactor in each of these events.

### 4.3 Earthworks

Ensure that earthworks and trenching is completed with respect to installation personnel safety and applicable local and national legislation.

Ensure that all trenches are adequately roped off or barricaded to prevent accidental access and take care with respect to trenching locations and timing to allow appropriate access to equipment as required.

### 4.4 HPC equipment storage recommendations and conditions

Ensure that equipment is stored properly on site to ensure that it is protected from the weather and not exposed to rain. Packaging may be damaged when wet.

When storing equipment:

- Stack and protect boxes inside a fenced off area of the site.
- Protect from weather conditions; store in a dry place or cover with a waterproof tarpaulin.
- Ensure that only packing crates of similar sizes are stacked.
- Ensure a maximum height of two crates.
- Cabinets must be closed when leaving the site.



*Figure 3: Maximum stacking height of similar sized boxes.*

## 4.5

### High-power electrical connections

It is critical that the high-power electrical connections are done correctly to ensure safe, compliant, and warranted performance of the charging equipment.

#### Safety Warning!

##### To be installed by a certified professional

Only trained and competent electricians are authorized to perform this work.

- Ensure that the upstream power feeds are off and locked out throughout the work.
- The charging equipment must not be energized at any time during the installation. To ensure personnel and equipment safety, power will be applied for the first time during the commissioning phase.
- Ensure that the cables used meet the minimum requirements specified by the manufacturer.
- Ensure that the lugs are compatible with fine-strand cable and that the crimping die is correct for both the wire type and lug type.
- Double check lug, cable, and crimp die compatibility.



Figure 4: F type die from Klauke

- A small amount of copper jointing compound must be applied to the contact patch of all lug-to-copper busbar connections. This inhibits corrosion at the joint to maintain a good connection for the life of the charging system.
- Use a flat washer in contact with the top of the lug and a spring washer on top of the flat washer for all bolted lug connections.
- Torque all connections to the specified amount, and mark the torque with a paint pen immediately.
- Clearly label all cables. Relabel when a cable is shortened, if required.
- Mark all cables with color coded heat shrink.
- Do not cover the entire lug with heat shrink; leave one crimp mark showing so that the correct crimping tool stamp is shown.

## 4.6 Isolated power unit installation

### 4.6.1 Access and clearance

To maintain accessibility and serviceability of the unit via the cabinet doors, the front and rear of the IPU should be spaced at least 1 m from any walls. This also aids in ventilation of the units.

If the IPU cabinets are required to be serviceable to the point where the primary IPU transformer may be removed in the future, make allowance for enough spacing between the rear of the unit to fit the length of a forklift and associated lifting tines, with additional appropriate space.

### 4.6.2 Foundation - precast preparation

Foundation design and preparation is the responsibility of the customer. Device footprints are provided by the manufacturer for hole drilling and conduit/cable location guidance.

For a full-scale drawing of Figure 5 and Figure 6, see the following documents respectively:

- IPU Foundation Template
- IPU Cable Entry Diagram

**Note:** A mounting stencil may be supplied by the manufacturer at customer request. All lengths in the below figures are specified in millimeters.

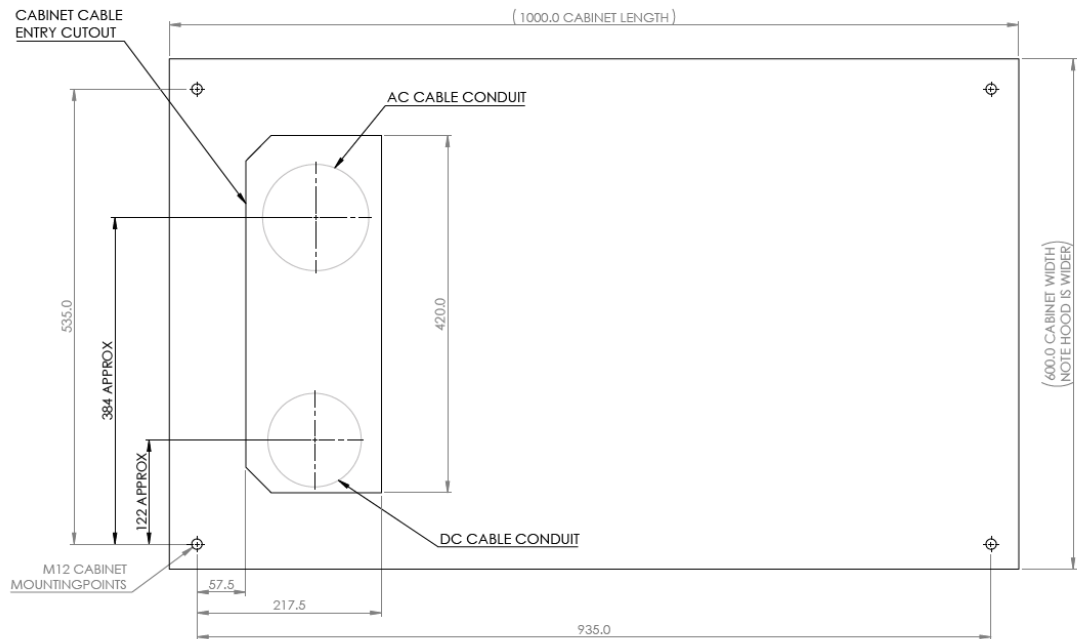

Figure 5: IPU foundation template

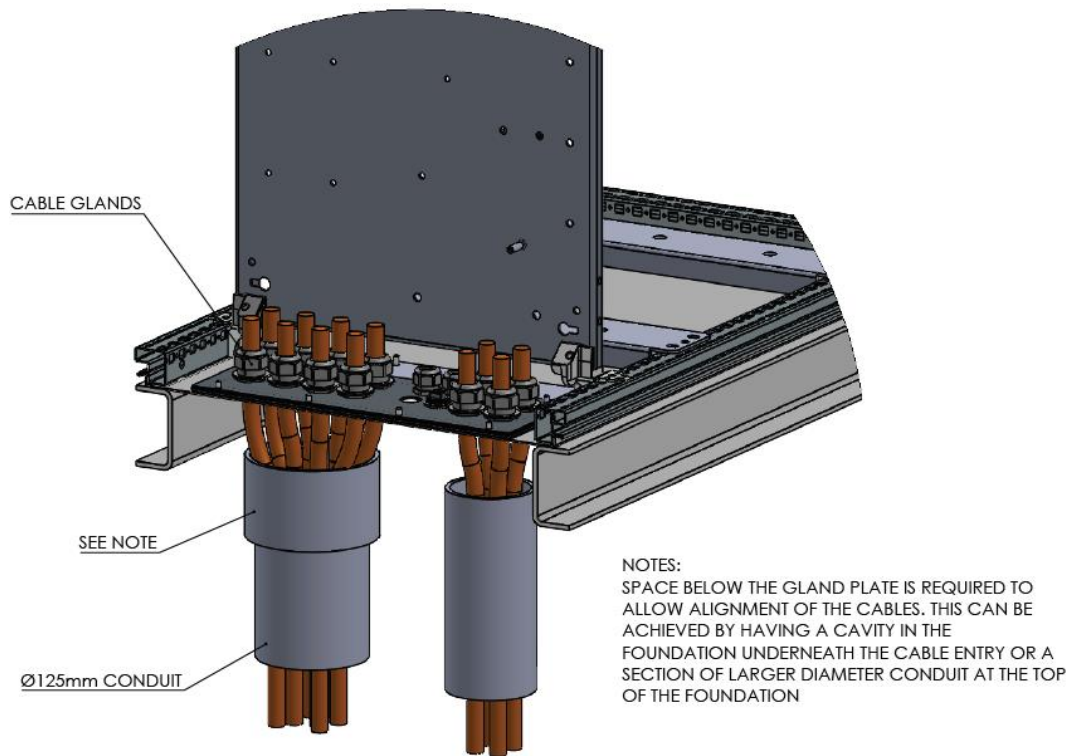

Figure 6: IPU cable entry diagram

After the foundation is prepared:

1. Ensure that all cables are pulled and labelled correctly according to the cabling plan.
 

**Notes:**

  - Ensure that the cables and cable glands are sealed under the metal plate. If not, use NORFIRNO Cable Sealant to seal.
  - For more information, see TRI125.INS.016 JuicePump RT 175-S Piping and Cabling.
2. Cut the mounting rods down to 50 mm above the foundation ground.
3. Deburr then straighten the threads.
4. Clean the slab of dust and debris.
5. Apply anti-seize to rods and temporarily fasten with an M12 nut and flat washer.

### 4.6.3

### Unbox and install the IPU

1. Locate the IPU box that is specially marked and contains the set of lifting eyes and straps.
2. Remove the top and side cardboard panels.
3. Open the lifting kit and attach the M12 load-rated lifting eyes (1.2 T), lifting slings, and protective pads to the four lifting points located in each corner on top of the cabinet.

#### **Warning!**

##### **Danger when lifting Units**

The rain hood and spacers are not appropriately rated for lifting the unit. Failure to remove them may cause damage to the IPU and/or serious accident.

4. Use a torque wrench to tighten the lifting eyes.  
**Note:** Use recommended torque settings when fastening lifting eyes; the settings are written on the parts.



Figure 7: View of lifting slings attached to the unit

5. Carefully crane the IPU into place, bolt the IPU down, then detach the crane.  
**Important:** Ensure that the IPU is properly secured by the bolts before you detach the crane.

**Note:** If lifting the IPU from a horizontal position to stand it up-right, it must still be lifted with all four lifting points attached to the slings going to a central lift point. Only two slings will be under tension, the other two will act as safety.

#### **Warning!**

NEVER lift the IPU in a horizontal position if the primary transformer has been installed. The cabinet is not rated for this.

#### 4.6.4

#### Terminate the IPU unit DC link

### Safety Warning!

#### Piping and wiring

Prior to installation of the piping and wiring, a professional review of local requirements must be performed to ensure that laws and regulations are adhered to. As a result, it may be necessary to deviate from the cable lug sizes (and corresponding cable sizes) referenced in this section.

1. Identify the DC output cables for the rectifier pack of the power unit.  
**Note:** These are contained within conduit B as shown in *TRI125.INS.016 JuicePump RT 175-S Piping and Cabling*.
2. Measure, cut, and crimp with M10 cable lugs to the DC mounting points.  
**Note:** Pull approximately 2 m of cable to allow termination to the DC terminals.

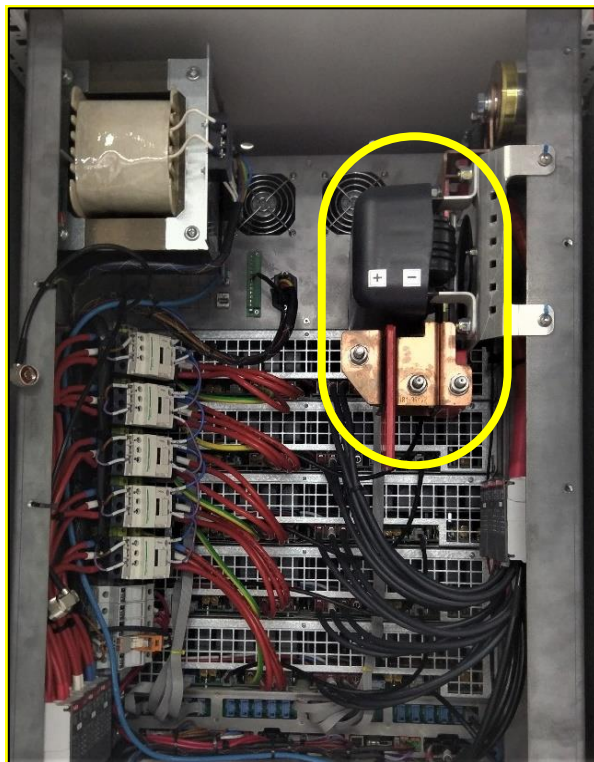

Figure 8: IPU DC output terminals

3. Measure, cut, and terminate the UU earth with an M10 cable lug to a spare mounting point on the gear tray earth bar.



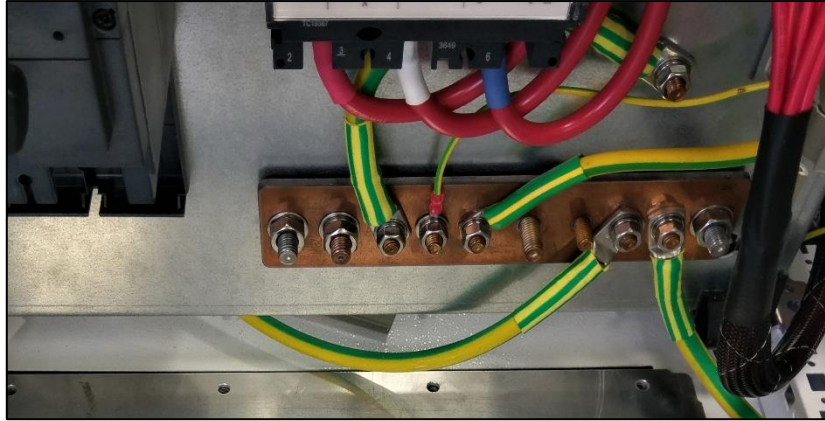

Figure 9: IPU earth terminals

#### 4.6.5 Terminate the IPU AC link

1. Identify the AC input cables.  
**Note:** These are contained within conduit A as shown in *TRI125.INS.016 JuicePump RT 175-S Piping and Cabling*.
2. Measure, cut, and crimp with M10 cable lugs to mounting points L1, L2, and L3 on load break switch Q0, located on the bottom-left of the main gear tray.

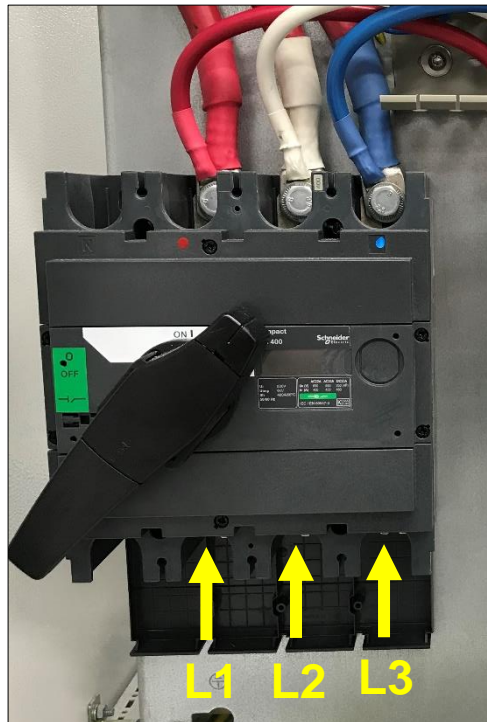

Figure 10: IPU 3 phase AC input isolation switch (Q0)

3. Measure, cut, and crimp the protective Earth with an M10 cable lug to a spare mounting point on the gear tray earth bar.

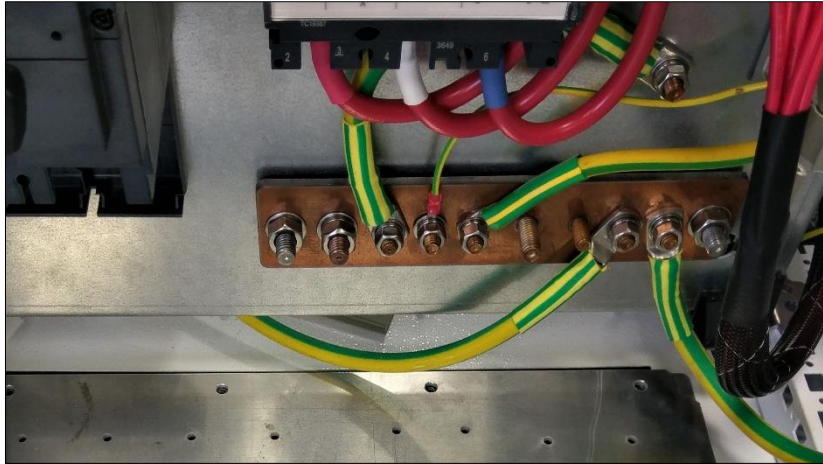

Figure 11: IPU earth terminals

#### 4.6.6 Terminate earthing electrodes

### **Caution!**

#### **Earthing electrode**

- For EMC compliance, it is important that a local earthing electrode is used to bond the chassis of the IPU directly to ground. This may be in the form of an earth stake, or if available, can be bonded to pre-existing buried earth structures.
- Prior to installation of the unit, a professional review of local lightning protection requirements must be performed to ensure that laws and regulations are adhered to. As a result, it may be necessary to install additional earthing electrodes for outdoor installations.

Terminate the earth electrodes to the IPU earth busbar as shown in section 4.6.5 *Terminate the IPU AC link*. If metal foundation plates are used, terminate to each IPU chassis or earth busbar.

#### 4.6.7 Terminate low-power and data cables

All low-power field wiring (excluding communications) to the UU is to be terminated into terminal block X1 (Figure 12).

**Note:** IMI earth reference field wiring terminal is not depicted in the following image.

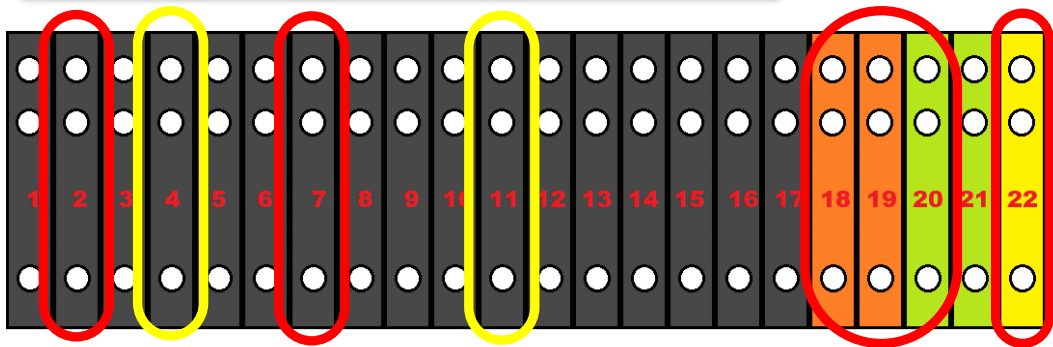
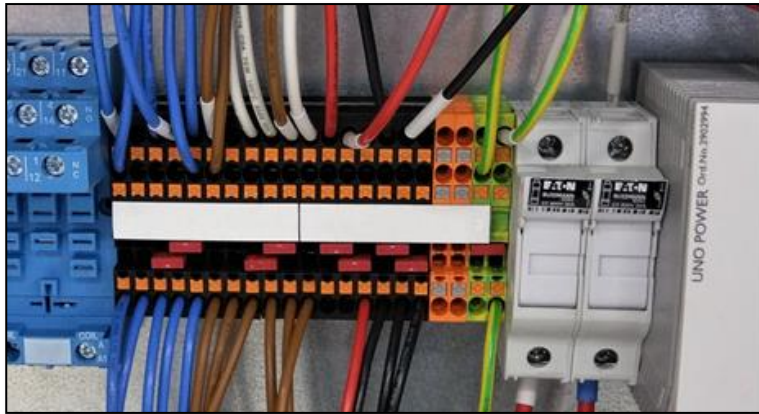

Figure 12: IPU terminal block X1 – Red highlights showing customer field wiring. Yellow highlights show optional wiring.

- Strip, bootlace (only if stranded wire; skip bootlace if solid core), and insert the wires into the field wiring terminals as follows:

Terminal	Wire
2	<ul style="list-style-type: none"> <li>UU 230 VAC Neutral</li> </ul>
7	<ul style="list-style-type: none"> <li>UU 230 VAC Line</li> </ul>
18	<ul style="list-style-type: none"> <li>UU 24 V Safety Loop</li> </ul>
19	<ul style="list-style-type: none"> <li>UU 24 V Safety Loop</li> </ul>
22	<ul style="list-style-type: none"> <li>IMI earth reference (from supply)</li> <li>IMI earth reference (to user unit)</li> </ul>
11	<ul style="list-style-type: none"> <li>(Optional) upstream breaker shunt output 230 VAC Line</li> </ul>
4	<ul style="list-style-type: none"> <li>(Optional) upstream breaker shunt output 230 VAC Neutral</li> </ul>

- Locate the Ethernet cable from the control shelf and use the tool-less jack from the installation kit to terminate the Cat6a cable.
 

**Note:** Use color code A for all Cat connections.
- Cover the Ethernet jack in heat shrink and secure it to the frame of the IPU.
- Connect a 1 m patch lead from the Ethernet jack to the control shelf.
 

**Note:** Alternatively, terminate the cable directly with a male connector and insert this into the control shelf.



Figure 13: Cat6a tool-less example Ethernet terminations

## 4.7 UU installation

### 4.7.1 Foundation preparation

**Note:** If the UU is to be located a distance greater than 100 m from the IPU, optical fiber is required for communication in place of Cat6a.

Foundation design and preparation is the responsibility of the customer. Device footprints are provided by the manufacturer for hole drilling and conduit/cable location guidance. For further details, please refer to *TRI125.INS.001 JuicePump RT 175-S User Unit Installation Manual*.

**Note:** A mounting stencil may be supplied by the manufacturer at customer request.

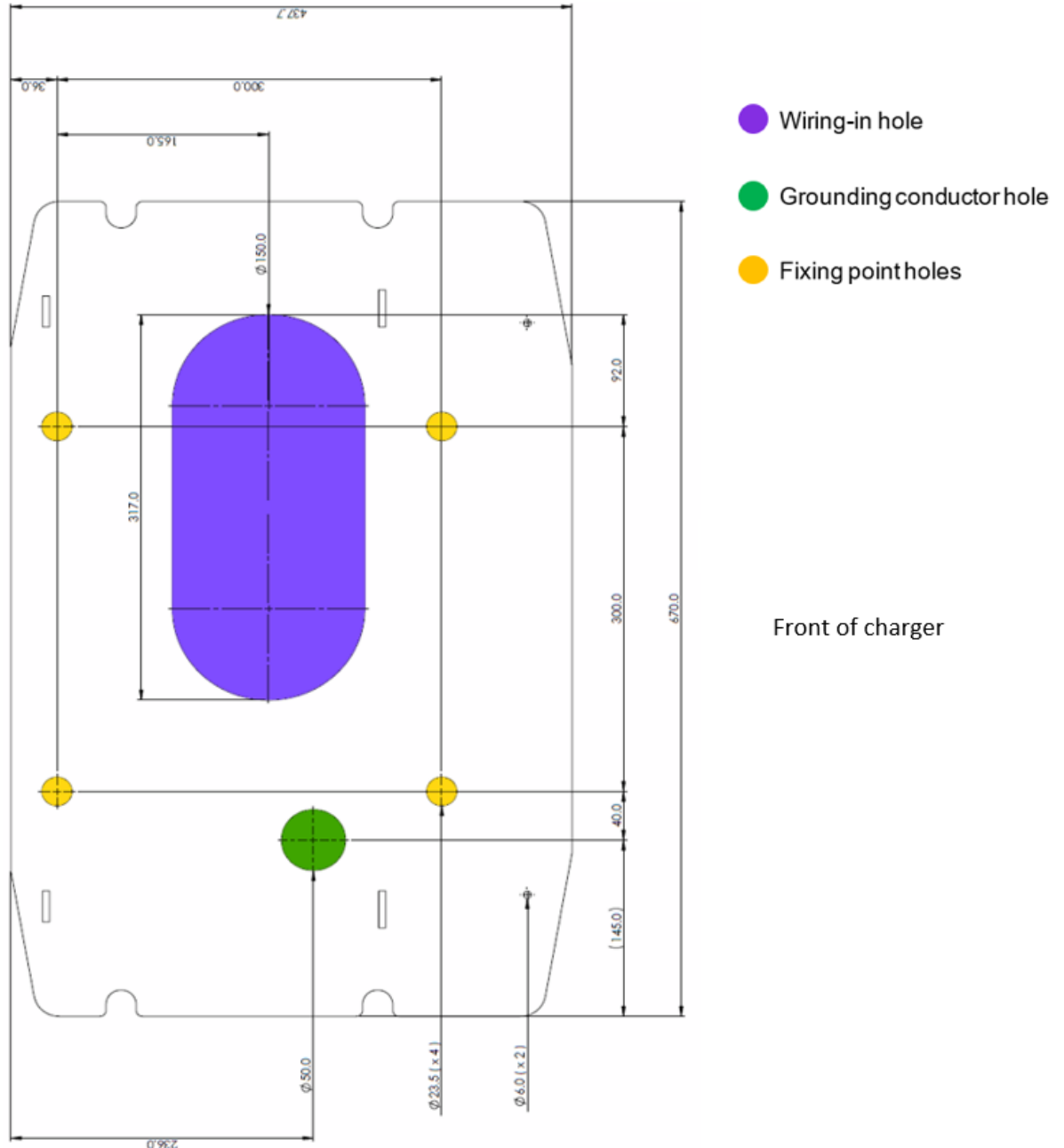

Figure 14: UU baseplate dimensions

1. Ensure that all cables are pulled and labelled correctly.  
**Note:** ensure the cables are cut with enough length (approx. 1 meter) to allow termination to the UU.
2. Ensure that conduits are cut to 70 mm from the foundation ground.
3. Cut the M16 mounting rods down to 50 mm from the foundation ground.  
**Note:** Do not use less than M12.
4. Clean the foundation of any debris.
5. Inspect the mounting rods to ensure they are straight, and the threads are clean.



Figure 15: UU foundation preparation

## 4.7.2 Unboxing and craning

1. Remove the lid and walls from the shipping box.  
**Note:** For more information, see *TRI125.INS.019 JuicePump RT 175-S UU Installation Manual*.



Figure 16: UU lifting points (indicative)

2. Attach lifting straps to the crane.
3. Slowly lift the UU until it is clear of the ground.

## **Warning!**

**Be aware that lifting heavy loads that are inadequately secured, could damage the product, and cause serious injury.**

Be careful as the unit may swing. A second operator may be required to control the user unit lift.

4. Lower the unit to the ground in a vertical position, using the crane to keep tension.
5. Remove the protective plastic wrapping from the lower portion of the UU.
6. Remove the screws that hold the front lower panel.
7. Remove the front lower panel and store it in a safe location to prevent damaged or scratching.
8. Remove the timber base plate.
9. Use the crane to lift the UU in place over the foundation.
10. Feed the cables through the hole in the foundation plate.
11. Align the rods from the foundation through the mounting holes in the base, and then lower the UU into place.
12. Ensure that the plastic grommets are inserted into the foundation plate.
13. Apply anti-seize compound to the mounting rods.
14. Use M16 nuts and flat washers to fasten the UU to the foundation, then torque to 40 Nm (or 30 Nm for M12).
15. Stow cables beneath the UU for protection until ready for cable termination (see Figure 17).



Figure 17: Mounted UU, and UU cable storage (images indicative only)

### 4.7.3

### Terminate earthing electrode



## Warning!

#### Earthing electrode

- For EMC compliance, it is important that a local earthing electrode is used to bond the chassis of the UU directly to ground. This may be in the form of an earth stake, or if available, can be bonded to pre-existing buried earth structures.
- Prior to installation of the UU, a professional review of local lightning protection requirements must be performed to ensure that laws and regulations are adhered to. As a result, it may be necessary to install additional earthing electrodes for outdoor installations.

Terminate the local earth electrode to the body of the UU on the same stud as the protective earth cable (Figure 18: UU earth stud location).

### 4.7.4

### Terminate protective earth cable

1. Identify the large protective earth cable from the marked cables.
2. Measure and cut to required length to terminate to stud located in Figure 18: UU earth stud location.

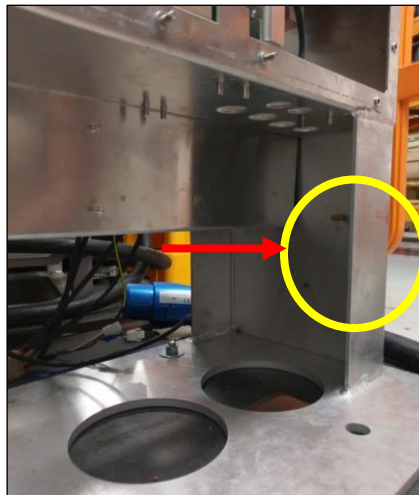

Figure 18: UU earth stud location

3. Terminate M8 lug to cable.
4. Apply green/yellow heat shrink to cable.
5. Apply aluminum jointing compound to the contact area.
6. Use an M8 spring washer and nut to fasten the cable to the earthing stud.
7. Tighten to 16 Nm and apply a torque mark.



#### 4.7.5 Terminate DC input cables

1. Identify and individually feed each DC power cable through its respective gland then measure, cut, and terminate with an M10 lug.

**Notes:**

- Depending on the site design, there may be up to two DC+ and two DC- cables. To maintain device IP rating, ensure that unused holes are appropriately sealed.
  - Ensure that the cables sit correctly in the glands and tighten them to ensure that no water or debris can enter. If in doubt, use an appropriate outdoor-rated sealant.
2. Apply copper jointing compound to the mating surfaces.
  3. Use an M10 spring washer and nut to fasten the cable to the stud.
  4. Tighten to 30 Nm and apply torque marks.



Figure 19: UU DC termination point

#### 4.7.6 Terminate safety loop cable

1. Feed the safety loop cable through the gland.  
**Note:** If a 3-core cable is supplied, only 2 cores are required, the third (earth) conductor should be taped and stowed.
2. Strip and apply bootlaces to the cable if stranded; no bootlace if solid core.
3. Insert the cable into the green connector on the tilt sensor PCB, the polarity of this connection does not matter.

**Note:** This is the PCB located on the bottom-right of Figure 19.

#### 4.7.7 Terminate single phase cable

1. Feed the single-phase cable through the gland.  
**Note:** When terminating the 3-core cable, do not terminate the earth to common chassis earth terminal. This core will be used for the IMI reference point.
2. Strip and apply bootlaces to the cable if stranded, no bootlace if solid core.
3. Insert the cable into the designated field wiring terminals to the top-left of the connection box.  
**Note:** For internal wiring, brown denotes 230 VAC line and blue denotes 230 VAC neutral.
4. Close the hatch and tighten all cover screws to 2 Nm.

## 4.7.8

### Terminate Ethernet cable

1. Unscrew the Ethernet IP connector from the HMI screen.
2. Slide housings mating half over the Ethernet cable coming from the conduit.  
**Note:** Ensure that the housing does not slide all the way back into the conduit.
3. Terminate the Ethernet cable into the Cat6a tool-less jack from the installation kit using Mode A.  
**Note:** Ensure that you connect shield to equipment ground on both the IPU and UU ends.



Figure 20: Cat6A tool-less.

4. Slide the housing cover back up over the jack as shown in Figure 21.



Figure 21: Terminated Ethernet jack.

5. Remove and discard Female to Female inline connector from the housing.
6. Connect the Ethernet cable from the HMI and close the housing.  
**Note:** Make sure that the housing is tightened in the middle and at the two end nuts to ensure a waterproof seal.

## 5 Site installation handover

Complete *TRI125.CHK.008 JuicePump RT 175-S System Installation Checklist* and attach photos of the installation.

### 5.1 Pre-checks

1. Check strain relief on power cables.
2. Check the earths are attached on removable panels and doors.
3. Check to see if there is any remaining liquid or dust and clean the site.

### 5.2 Polarity, cross-wire, and bolted short test

#### 5.2.1 DC link test

1. Use a DMM and a long piece of wire to perform a continuity test between each of the items in the following table:

UU	Power Unit	Pass Criteria
Earth	DC +	NC
	DC -	NC
	Earth	Connected
DC +	DC +	Connected
	DC -	NC
	Earth	NC
DC -	DC +	NC
	DC -	Connected
	Earth	NC

## 5.2.2

### AC link test

1. Use a DMM and a long piece of wire to perform a continuity test between each of the items in the following table:

Power Unit (Isolation Switch)	Upstream Supply	Pass Criteria
Earth	L1	NC
	L2	NC
	L3	NC
	Earth	Connected
L1	L1	Connected
	L2	NC
	L3	NC
	Earth	NC
L2	L1	NC
	L2	Connected
	L3	NC
	Earth	NC
L3	L1	NC
	L2	NC
	L3	Connected
	Earth	NC

## 5.2.3

### Waste management, tidy up, and report

1. Finalize any waste pick up and cleaning operations, and tidy up the site.
2. Send the full report to the manufacturer and all other parties involved via *TRI125.CHK.008 JuicePump RT 175-S System Installation Checklist* and include the pictures to support the signed checklist.